



OMEGA 700 X

OMEGA 700 X
Cod. **02003310** EAN **8422248190602**

- Mechanical control panel**
- 3 extraction levels
- Extraction power (according to UNE/EN 61591): **645m³/h** - 385m³/h
- Maximum air flow: **1115m³/h**
- Sound power (Reg.(EU) n°65/2014): 58dB(A)**, maximum: 72dB(A)
- M3R motor. Extra silent. Maximum energy consumption **270W**
- High efficiency compact LED strip**
- Easy-to-install system
- Dishwasher-washable filters
- Max. pressure 430 Pa
- 150/125 mm outlet diameter
- Energy Class: C

► **Accessories (not included)**

Active charcoal filterCod. 02859391 / EAN 8422248001595
 Check valveCod. 02832001 / EAN 8422248044677
 Top tubeCod. 02862400 / EAN 8422248020435

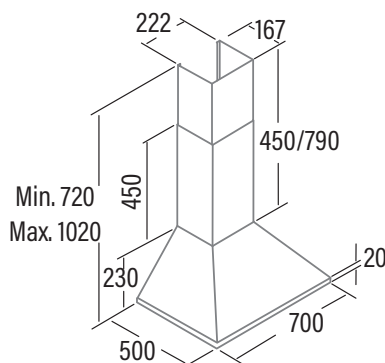

Code	02003310
EAN	8422248190602
Model	OMEGA 700 X
Type	Chimney
Product fiche according to directives EU65/2014 - EN61591, EN60704-2-13, EN50564	
AEC (Annual Energy consumption) (kWh/annum)	95,4
EEL class (Energy Efficiency Class)	C
FDE (Fluid Dynamic Efficiency)	17,8
FDE class (Fluid Dynamic Efficiency Class)	D
LE (Lighting Efficiency) (lux/W)	26
LE class (Lighting Efficiency Class)	B
GFE (Grease Filtering Efficiency)	90,3
GFE Class (Grease Filtering Efficiency class)	B
Air flow at minimum speed (m3/h)	385
Air flow at maximum speed (m3/h)	645
Air flow at intensive speed (TURBO) (m3/h)	-
Sound Power Level at minimum speed (dB)	57,8
Sound Power Level at maximum speed (dB)	71,8
Sound Power Level at intensive speed (TURBO) (dB)	-
Po (Power Consumption in off mode) (W)	0
Ps (Power Consumption in standby) (W)	0
Integration directive EU 66/2014	
f (Time Increase Factor)	1,4
EEL (Energy Efficiency Index)	81,3
QBEP (Flow Rate at Best Efficiency Point) (m3/h)	371,8
PBEP (Static Pressure Difference at Best Efficiency Point) (Pa)	314
WBEP (Electric Power Input at Best Efficiency Point) (W)	182,5
WL (Nominal Power Consumption of Lighting system) (W)	3
EMIDDLE (Average Illumination of Lighting system on Cooking surface) (lux)	78
External Dimensions	
Width (mm)	700
Depth (mm)	500
Total max height(mm)	1010
Total min height(mm)	720
Outlet Diameter (mm)	150/125
Characteristics	
Motor	M3R
Extraction Levels	3
Motor Maximum Power Consumption	270
Maximum Pressure	430
Intensive Speed (TURBO) Pressure	-
Control Type	Mechanic
Automatic shut-down timer	-
Electronic Filter Saturation Indicator	-
Filter Type	Metallic
Anti-grease Filter Number	2
Inner Shield	-
Lighting	
Light Type	CSLED
Adjustable Intensity Lighting	-
N° of Lamps	1
Installation	
Minimum height distance to a electric worktop hob (mm)	650
Minimum height distance to a gas worktop hob (mm)	650
Installation with Outlet tube to the exterior / Recirculating	BOTH
Easy Installation System	√
Electric Connection	
Total Rush Power (W)	273
Rated Voltage (V)	220-240
Network Frequency (Hz)	50
Electrical Insulation Class	CLASS II
Plug	No
Accessories	
Upper Decorative tube Extension	02862400
White Decorative Tube	-
Black Decorative Tube	-
Island Tube Enhancer	-
Check Valve	02832001
MAX PRO Metal Filter	02800917
Metal Filter	02800905*
DUAL Filter (metal + active charcoal)	02800918
Active Charcoal Filter	02859391
Noiseless Flexible Duct	02893002