



## BENU SLIM ISLAND



BENU SLIM 900 ISLAND  
Cod. **02111306** EAN **8422248094313**

- ❑ **Touch control** panel with automatic shut-down timer and cleaning filters indicator + **remote control**
- ❑ **AUTO connectivity** with automatic control from the **CATA hob**
- ❑ 4 extraction levels, 3 + 1 **TURBO**
- ❑ Extraction power (according to UNE/EN 61591): **620m<sup>3</sup>/h** - 300m<sup>3</sup>/h
- ❑ Maximum air flow (free outlet): **950m<sup>3</sup>/h**
- ❑ **Sound power (Reg.(EU) n°65/2014): 50dB(A)**, maximum: 65dB(A)
- ❑ S6 motor. Extra silent. Maximum energy consumption 105W
- ❑ **High-efficiency lighting** by intensity-adjustable two-tone warm / natural **LED STRIP**
- ❑ Easy-to-install system
- ❑ Dishwasher-washable filters
- ❑ **Inox finishing**
- ❑ Max. Pressure: 470 Pa
- ❑ 150 mm outlet diameter
- ❑ **Minimum installation height 17 cm**
- ❑ Ceiling installation

► **Accessories (not included)**

Active Charcoal Filter ..... Cod. 02859398 / EAN 8422248075497  
Adaptator+Check Valve 150mm ..... Cod. 02832006 / EAN 8422248079167

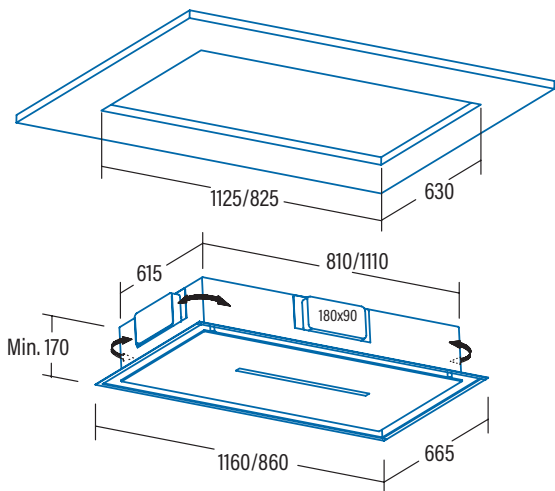

<b>Code</b>	<b>02111306</b>
<b>EAN</b>	<b>8422248094313</b>
<b>Model</b>	<b>ISLA BENNU SLIM 900 X</b>
<b>Type</b>	Island
<b>Product fiche according to directives EU65/2014 - EN61591, EN60704-2-13, EN50564</b>	
AEC (Annual Energy consumption) (kWh/annum)	44,1
EEl class (Energy Efficiency Class)	B
FDE (Fluid Dynamic Efficiency)	25,2
FDE class (Fluid Dynamic Efficiency Class)	B
LE (Lighting Efficiency) (lux/W)	23,7
LE class (Lighting Efficiency Class)	B
GFE (Grease Filtering Efficiency)	91,2
GFE Class (Grease Filtering Efficiency class)	B
Air flow at minimum speed (m <sup>3</sup> /h)	300
Air flow at maximum speed (m <sup>3</sup> /h)	500
Air flow at intensive speed (TURBO) (m <sup>3</sup> /h)	620
Sound Power Level at minimum speed (dB)	50
Sound Power Level at maximum speed (dB)	65
Sound Power Level at intensive speed (TURBO) (dB)	67
Po (Power Consumption in off mode) (W)	0,3
Ps (Power Consumption in standby) (W)	0
<b>Integration directive EU 66/2014</b>	
f (Time Increase Factor)	1,1
EEl (Energy Efficiency Index)	60,7
QBEP (Flow Rate at Best Efficiency Point) (m <sup>3</sup> /h)	326,9
PBEP (Static Pressure Difference at Best Efficiency Point) (Pa)	269,4
WBEP (Electric Power Input at Best Efficiency Point) (W)	97,1
WL (Nominal Power Consumption of Lighting system) (W)	7
EMIDDLE (Average Illumination of Lighting system on Cooking surface) (lux)	166
<b>External Dimensions</b>	
Width (mm)	900
Depth (mm)	500
Total max height (mm)	170
Total min height (mm)	170
Outlet Diameter (mm)	180x90
<b>Characteristics</b>	
Motor	S6
Extraction Levels	3+1
Motor Maximum Power Consumption	105
Maximum Pressure	370
Intensive Speed (TURBO) Pressure	470
Control Type	TC4i
Automatic shut-down timer	√
Electronic Filter Saturation Indicator	√
Filter Type	Metallic
Anti-grease Filter Number	2
Inner Shield	-
<b>Lighting</b>	
Light Type	SSLED
Adjustable Intensity Lighting	√
N° of Lamps	1
<b>Installation</b>	
Minimum height distance to a electric worktop hob (mm)	550
Minimum height distance to a gas worktop hob (mm)	660
Installation with Outlet tube to the exterior / Recirculating	BOTH
Easy Installation System	√
<b>Electric Connection</b>	
Total Rush Power (W)	112
Rated Voltage (V)	220-240
Network Frequency (Hz)	50
Electrical Insulation Class	CLASE I
Plug	-
<b>Accessories</b>	
Upper Decorative tube Extension	-
White Decorative Tube	-
Black Decorative Tube	-
Island Tube Enhancer	-
Check Valve	-
MAX PRO Metal Filter	-
Metal Filter	02800930
DUAL Filter (metal + active charcoal)	02800922
Active Charcoal Filter	-
Noiseless Flexible Duct	-