



V-7000 X



V-7000 X

Cod. **02085301** EAN **8422248108478**

- Mechanical control panel
- 3 extraction levels
- Extraction power (according to UNE/EN 61591): **480m³/h** - 320m³/h
- Sound power (Reg.(EU) n°65/2014): **52dB(A)**, maximum: 64dB(A)
- 1 motor. Extra silent. Maximum energy consumption **120W**
- High efficiency Strip LED lighting
- Energy Class: C

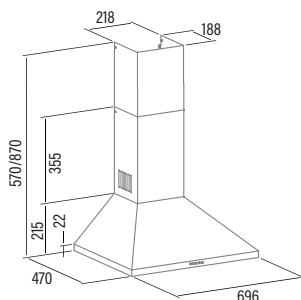

Code	02085301
EAN	8422248108478
Model	V-7000 X
Type	Chimney
Product fiche according to directives EU65/2014 - EN61591, EN60704-2-13, EN50564	
AEC (Annual Energy consumption) (kWh/annum)	60
EEL class (Energy Efficiency Class)	C
FDE (Fluid Dynamic Efficiency)	11,3
FDE class (Fluid Dynamic Efficiency Class)	E
LE (Lighting Efficiency) (lux/W)	29,7
LE class (Lighting Efficiency Class)	A
GFE (Grease Filtering Efficiency)	62,5
GFE Class (Grease Filtering Efficiency class)	E
Air flow at minimum speed (m3/h)	321,1
Air flow at maximum speed (m3/h)	478,9
Air flow at intensive speed (TURBO) (m3/h)	-
Sound Power Level at minimum speed (dB)	52
Sound Power Level at maximum speed (dB)	64
Sound Power Level at intensive speed (TURBO) (dB)	-
Po (Power Consumption in off mode) (W)	0
Ps (Power Consumption in standby) (W)	0
Integration directive EU 66/2014	
f (Time Increase Factor)	1,6
EEL (Energy Efficiency Index)	83,6
QBEP (Flow Rate at Best Efficiency Point) (m3/h)	287,4
PBEP (Static Pressure Difference at Best Efficiency Point) (Pa)	140
WBEP (Electric Power Input at Best Efficiency Point) (W)	98,7
WL (Nominal Power Consumption of Lighting system) (W)	3
EMIDDLE (Average Illumination of Lighting system on Cooking surface) (lux)	89,2
External Dimensions	
Width (mm)	700
Depth (mm)	470
Total max height(mm)	870
Total min height(mm)	570
Outlet Diameter (mm)	150/125
Characteristics	
Motor	120W
Extraction Levels	3
Motor Maximum Power Consumption	120
Maximum Pressure	227
Intensive Speed (TURBO) Pressure	-
Control Type	Mechanic
Automatic shut-down timer	-
Electronic Filter Saturation Indicator	-
Filter Type	Metallic
Anti-grease Filter Number	3
Inner Shield	-
Lighting	
Light Type	CSLED
Adjustable Intensity Lighting	-
N° of Lamps	1
Installation	
Minimum height distance to a electric worktop hob (mm)	650
Minimum height distance to a gas worktop hob (mm)	650
Installation with Outlet tube to the exterior / Recirculating	BOTH
Easy Installation System	√
Electric Connection	
Total Rush Power (W)	123
Rated Voltage (V)	220-240
Network Frequency (Hz)	50
Electrical Insulation Class	CLASS I
Plug	-
Accessories	
Upper Decorative tube Extension	02863304
White Decorative Tube	-
Black Decorative Tube	-
Island Tube Enhancer	-
Check Valve	-
MAX PRO Metal Filter	-
Metal Filter	02859499
DUAL Filter (metal + active charcoal)	-
Active Charcoal Filter	02859496
Noiseless Flexible Duct	02893002